



Grade 460 Carbon Bar System

The standard form of tendon comprises a bar with a left and right hand threaded fork at opposite ends. Once installed the tendon can be adjusted in length by turning the bar.



Generally used for longer tendons, a turnbuckle giving +/- 50mm adjustment for M20 and above (+/- 25mm adjustment for smaller sizes) can be used where fork to fork tendons do not give adequate length adjustment. They can also be used where the overall length exceeds the maximum single bar length.

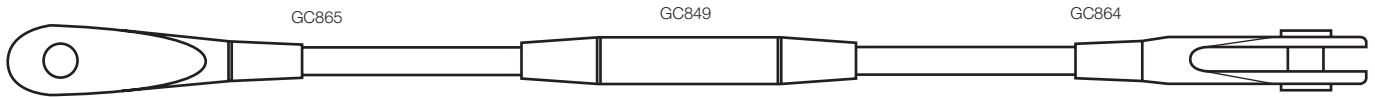

Where excessive sag in a horizontal bar is anticipated a welded connection cleat can be fixed to the turnbuckle for hanger and stay bars to be connected.

All components in this System are manufactured from Grade 460 steel with a 460N/mm² yield stress for sizes M20 and above and 355N/mm² for M12 and M16. Bars are available in diameters from M12 to M100 in long lengths (up to 12m). Threads are rolled to BS3643. Longer lengths are available by using turnbuckles.

All bars and fittings can be supplied in a self colour, painted or galvanized finish. If shot blasting, painting or galvanizing is performed by a third party, please ensure that all threads are protected as Great Circle Rigging cannot accept any responsibility for free running of threads once treated by others.

A variety of fittings can be supplied to match your requirements. Listed overleaf are the standard design fittings offered as part of our Grade 460 bar system. All fittings are designed to the requirements of BS5950 and exceed the capacity of the bar. We can also supply connection plates to suit forks, again with a finish to match

Mechanical Properties

		M12	M16	M20	M24	M30	M36	M42	M48	M56	M64	M76	M90	M100
Yield load (design load)	kN	30	56	112	162	258	375	515	677	933	1,231	1,768	2,547	3,188
Ultimate load (break load)	kN	51	95	149	215	342	498	683	898	1,238	1,632	2,345	3,377	4,228
Nominal bar diameter	mm	12	16	19	22	28	34	39	45	52	59	71	85	95
Stress area	mm ²	84	157	245	353	561	817	1,121	1,473	2,030	2,676	3,844	5,537	6,932
Yield stress	N/mm ²	355	355	460	460	460	460	460	460	460	460	460	460	460
Ultimate stress	N/mm ²	610	610	610	610	610	610	610	610	610	610	610	610	610
Elongation	%	20	20	19	19	19	19	19	19	19	19	19	19	19
Maximum single bar length	m	6	6	12	12	12	12	12	12	12	12	12	12	12
Weight/m (g)		890	1,390	2,230	2,980	4,830	7,130	9,380	12,480	16,670	21,460	31,080	44,540	55,640
Bar specification	Grade 460 bars to BS EN 10025-1, type S355J2G3 with enhanced mechanical properties as detailed M12 & M16 bars to BS EN 10025-1, type S355J2G3. all carbon steel bar is fully weldable													
Thread specification	Rolled metric threads to BS3643													
Length tolerance	+ / - 3mm for M12 to M100													
Weights	Weights quoted are for self colour. For galvanised add approximately 7%													

Threaded fork ends are used to terminate bars and transfer load to the structure. Fork ends are cast components from M12 - M100. The forks are threaded left or right hand depending on the tie rod arrangement.

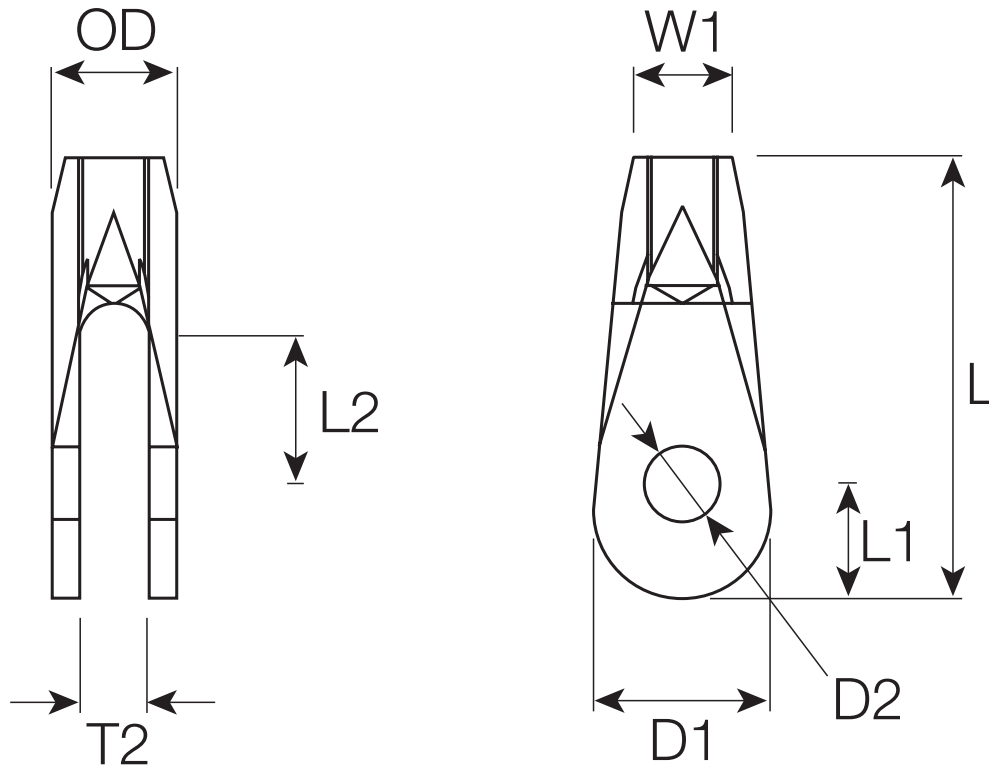

GC864/865 Forks (GC864 right hand thread, GC865 left hand thread)

		M12	M16	M20	M24	M30	M36	M42	M48	M56	M64	M76	M90	M100
Yield Load (design load)	kN	30	56	112	162	258	375	515	677	933	1,231	1,768	2,547	3,188
Fork length	L	90	112	132	155	189	217	238	266	313	348	420	498	575
Diameter	W1	18	22	29	35	43	52	60	68	80	91	108	129	143
Thickness	W2	24	28	35	42	52	62	74	84	95	120	148	170	181
Jaw gap +/-2mm	T2	14	16	19	24	30	34	39	44	49	59	76	86	91
Width	D1	32	43	51	62	79	93	107	121	145	167	199	246	287
Pin hole diameter	D2	13	17	21	25	31	37	43	49	57	65	78	96	111
Projection	L1	21	27	33	41	52	61	69	78	96	110	131	161	188
Jaw depth	L2	25	30	42	50	59	70	78	87	105	120	141	171	197
Adjustment per tendon +/-		15	15	15	20	20	20	25	25					
Weight (g)		400	600	1,100	1,500	3,000	4,000	10,000	12,000	18,000	25,000	40,000	56,000	80,000

all dimensions in mm

weights quoted are for self colour. For galvanised add approximately 7%

Pins, Tapered Nuts & Turnbuckles

Standard pins are supplied as a pin barrel with end caps. The end caps are secured with countersunk socket screws to provide a flush finish. Other pin details can be machined to your specific project requirements.

The tapered nut (lock cover) is a machined fitting which tapers the fork to the diameter of the bar. For the complete architectural look they also hide exposed threads and when tightened against the fork they lock the tendon at the set length. Where thread covers are not required standard hexagonal nuts can be used.

Turnbuckles are left and right hand threaded bar connectors used where additional adjustment is required or when the overall tendon length exceeds the maximum single bar length. These are machined with a central chamber to give greater length adjustment than can be achieved with the left hand/right hand fork combination.

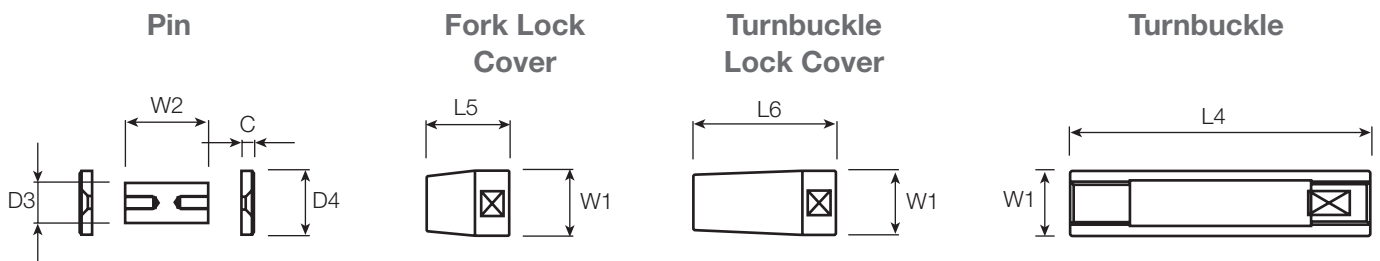

		M12	M16	M20	M24	M30	M36	M42	M48	M56	M64	M76	M90	M100
Pin diameter	D3	12	16	20	24	30	36	42	48	56	64	76	94	109
Pin body length	W2	24	28	35	42	52	62	74	84	95	120	148	170	181
End cap diameter	D4	20	25	32	35	50	55	60	60	70	86	100	120	140
End cap thickness	C	3	5	6	6	10	10	12	12	12	14	15	20	20
Lockcover diameter	W1	18	22	29	35	43	52	60	68	80	91	108	129	143
Fork lockcover length	L5	25	26	40	45	50	55	60	60	75	85	91	126	134
Turnbuckle lockcover length	L6	30	33	78	84	87	93	102	105	106	112	118	153	160
Turnbuckle diameter	W1	18	22	29	35	43	52	60	68	80	91	108	129	143
Turnbuckle length	L4	70	85	144	155	170	180	195	210	230	240	268	290	315

all dimensions in mm

Central Connection Discs

Where tendons cross in a braced bay, a central connection disc can be used. Tendons are usually fork to fork type but where greater adjustment or a pre-tension is required, fork-turnbuckle-fork can be used.

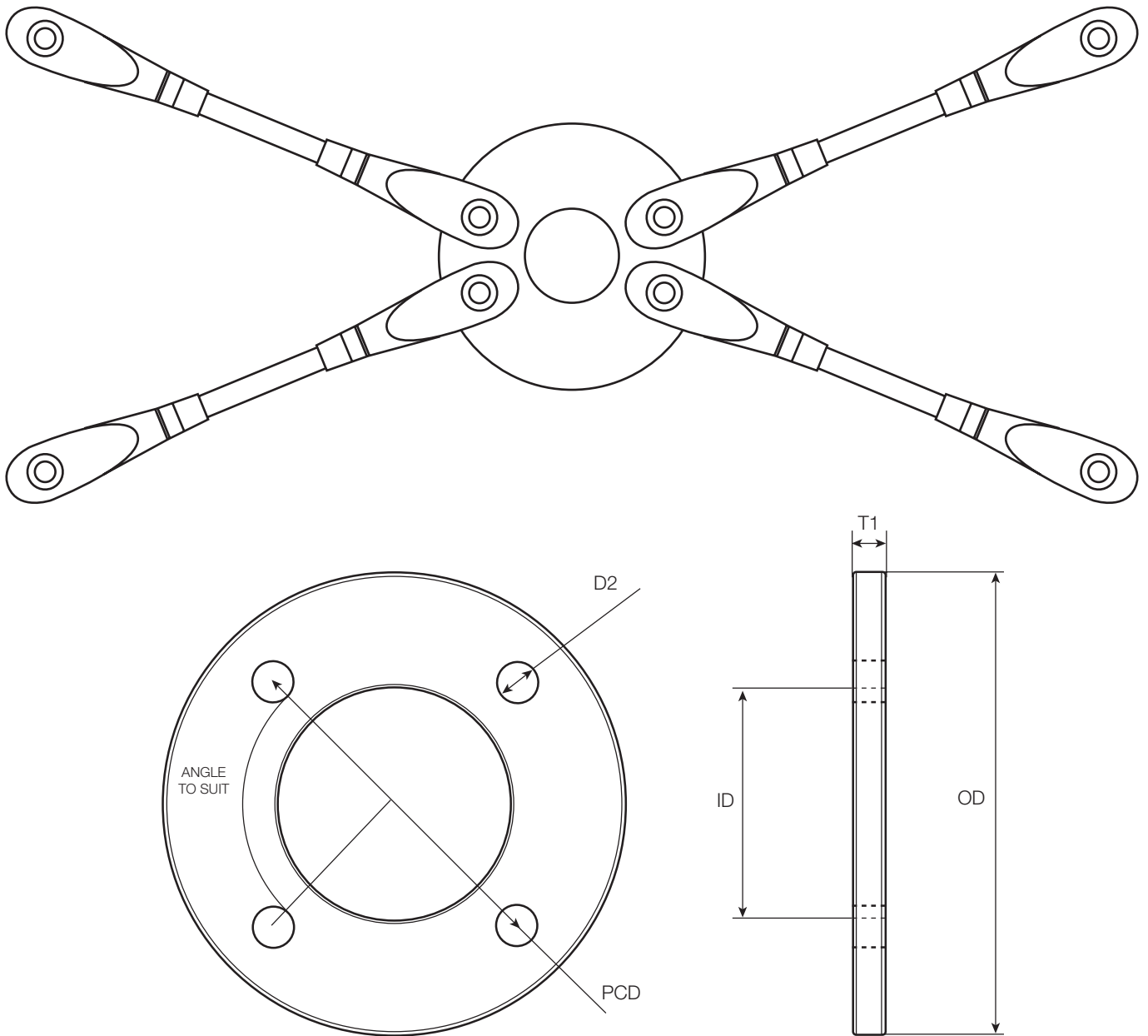

GC506 Central Connection Discs

		M12	M16	M20	M24	M30	M36	M42	M48	M56
Thickness	T1	10	12	15	20	25	30	35	40	45
Overall diameter	OD	145	185	245	285	350	420	490	560	660
Central hole	ID	50	60	70	90	100	120	140	160	200
Pin hole diameter	D2	13	17	21	25	31	37	43	49	57
Pin centre diameter	PCD	110	140	180	210	260	310	360	410	480

all dimensions in mm

○ Great Circle Rigging:

Great Circle Rigging
181-183 Coast Road
Cochrane Park
Newcastle Upon Tyne
NE7 7RR

T: +44 (0)191 240 0435

F: +44 (0)191 240 0436

enquiries@greatcirclerigging.co.uk

www.greatcirclerigging.co.uk

